

Ana Şanzıman ve Kamyon Modeli

DAIHATSU DELTA
DAIHATSU DHT 06
DAIHATSU H 260
DAIHATSU H 50
DAIHATSU M 150
DAIHATSU M 151
DAIHATSU M 153
DAIHATSU M 155
DAIHATSU M 52
HINO 300
HINO DUTRO

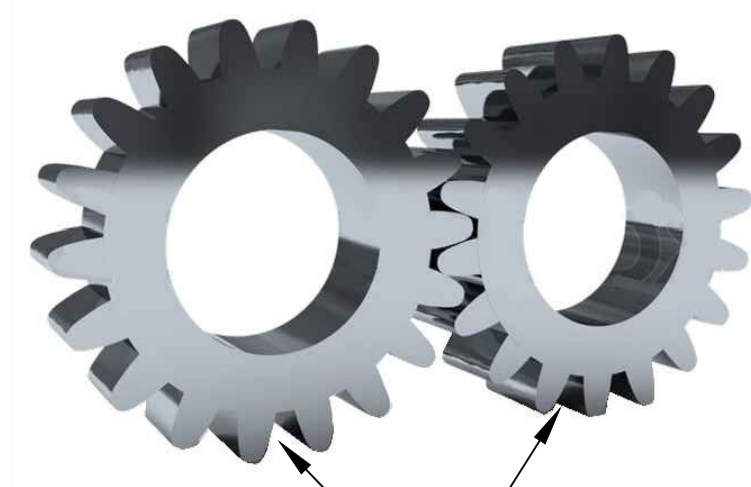

PTO Tipi
Çift Dişli

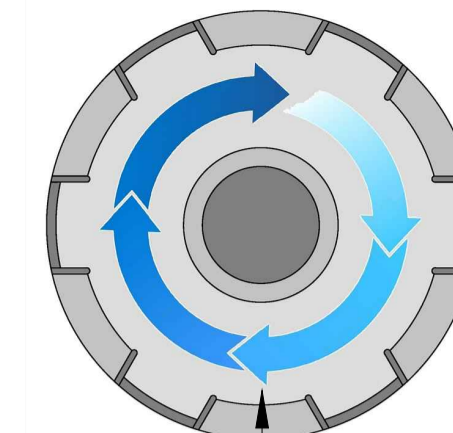

PTO Mil Dönüş Yönü
Sağa
(Saat Yönü)

Pto Kodu	329VE
Dişli Tipi	Sol Helis
Pto Tipi	Çift Dişli
Tork Nm	200
Güç Kw	18
Tahvil Oranı	0,93
Bağlantı Yeri	Sol Yan
Kontrol Sistemi	Vakumlu
Pto Mil Dönüş Yönü	Sağa
Ağırlık Kg.	11,50

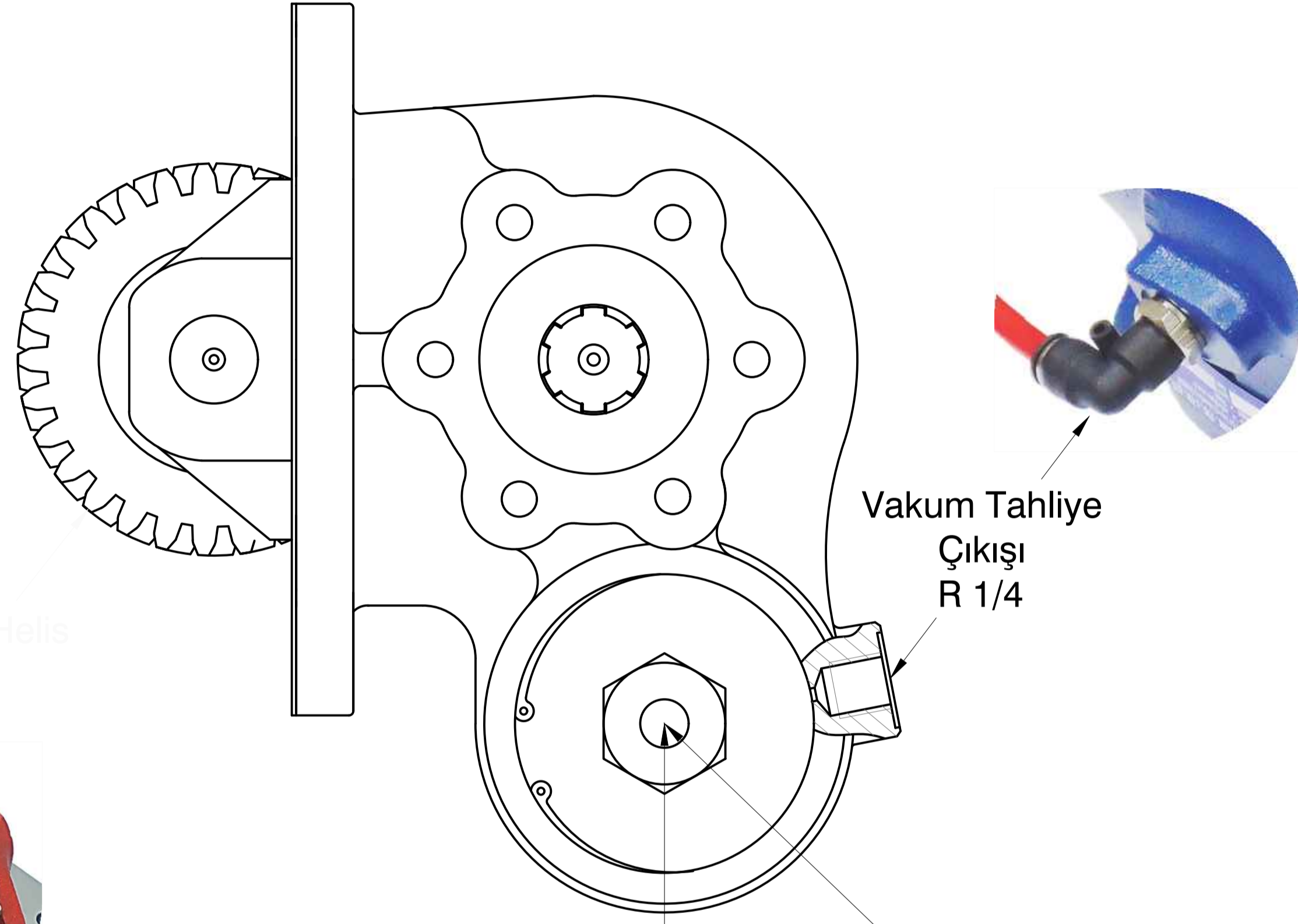

Vakum Girişi
R 1/4

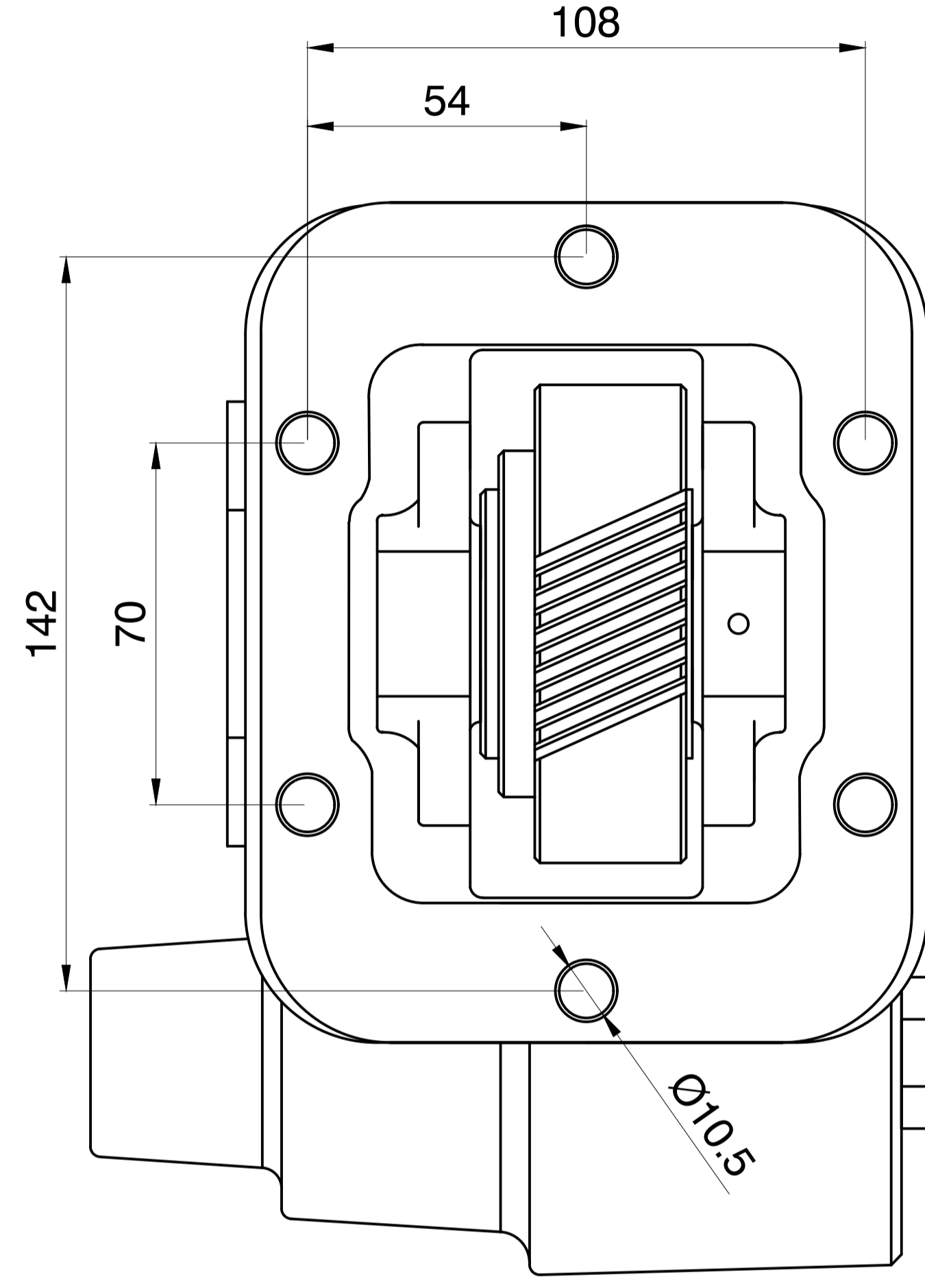

6 Kamalı
Frezeli Mil
6x21x25
21 UNI 222

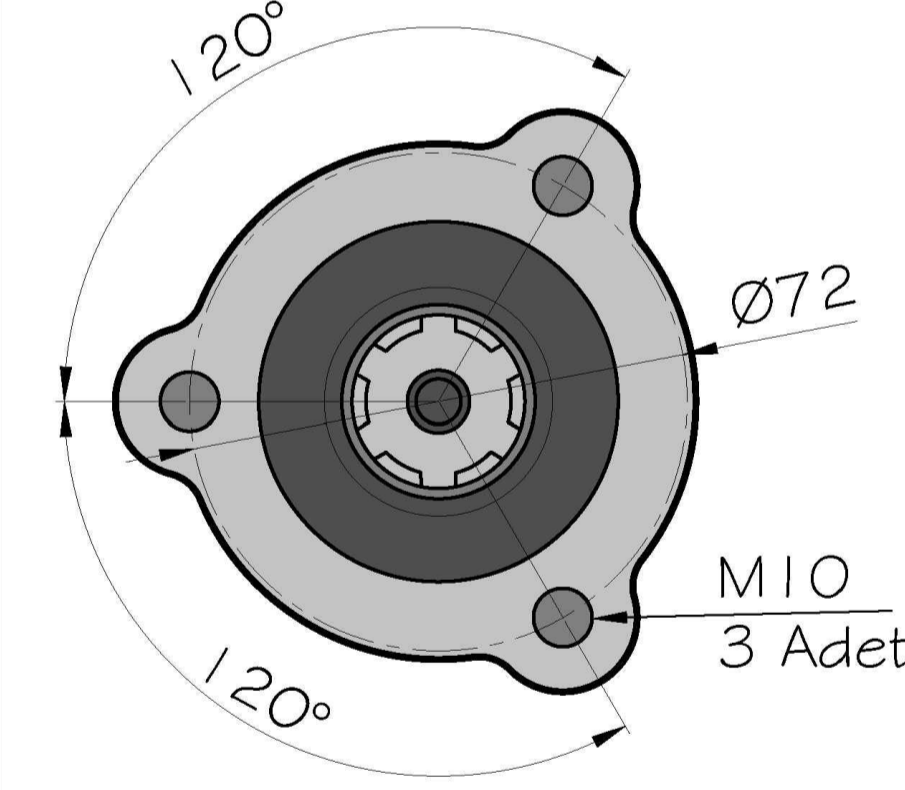

6 Kama
Frezeli
Mil
6x21x25
21 UNI 222



PTO Bağlantı Yeri
Aracın Sol Yanı

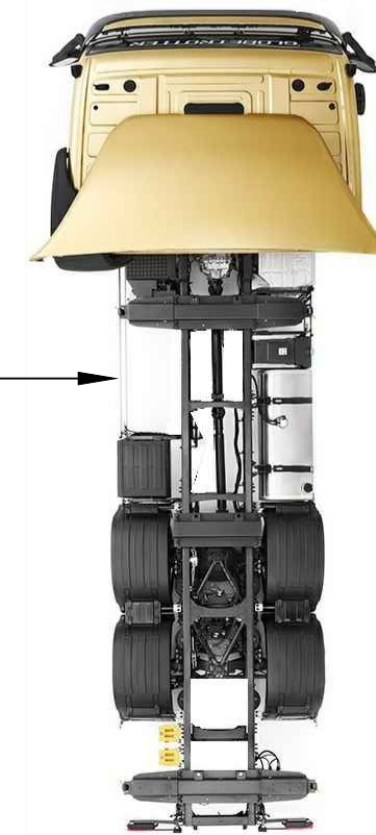

Ürün Kod Detayı
3 2 9 V E

6 Kama Freze Milli / 6x21x25
Vakumlu
Sıra No

